

ZOOMLION ARTICULATING BOOM LIFTS

ZA80J

Comply with CE Standard

HIGHLIGHTS

- 
- ▶ 550lb/250kg platform capacity for higher efficiency
 - ▶ Build-in multiple pressure control system to enhance stability
 - ▶ Precise load sensing system to improve overload safety operations
 - ▶ Platform fast lifting function provides high-efficient performance without tower boom operation
 - ▶ Hostile Kits available for a dusty working environment
 - ▶ Outstanding below ground reach of 5.1m
 - ▶ 86ft 11in/26.50m working height

FEATURES

Standard Features

Horn
All motion alarm
Proportional control
Self-closing entry gate
Flashing beacon
Auto-leveling system
Emergency stop button
Over tilt protection system
Emergency descent system
On-board diagnostic system
Oscillating axle
4.3' LED display
Load sensing system
Swing-out engine tray
Anti-collision device

Accessories & Options

- ▶ Platform work lights
- ▶ AC power to platform

ACCESS WITH ZOOMLION GREEN

Phone: 1 (833) USA-ZOOM
E-mail: sales@zoomlion-na.com

Add: Zoomlion Heavy Industry NA, Inc. 14215 Two Mile Road, Yorkville, WI 53126
Web: www.zoomlion-na.com

MAIN SPECS OF ARTICULATING BOOM LIFTS

ZA80J

Comply with CE Standard

Model	ZA80J	
	Imperial	Metric
Size		
Work Height	86ft 11in	26.5m
Platform Height	80ft 5in	24.5m
Horizontal Outreach	62ft	18.9m
Up and Over Height	30ft 11in	9.42m
A - Stowed Length	36ft 11in	11.25m
B - Stowed Width	8ft 2in	2.49m
C - Stowed Height	9ft 10in	3.0m
D - Platform Length	8ft	2.44m
E - Platform Width	2ft 12in	0.91m
Jib Length	6ft	1.83m
F - Wheelbase	10ft	3.05m
G - Ground Clearance	1ft 5in	0.42m
Performance		
Platform Capacity	551 lb	250kg
Drive Speed	3.11 mph	5.0km/h
Gradeability	45%(24°)	45%(24°)
Axles Oscillation	8in	0.2m
Turning Radius (Inside)	10ft 12in	3.35m
Turning Radius (Outside)	21ft 3in	6.48m
Swing	360° continuous	
Platform Rotation	±90°	
H-Tail Swing	0.94m/3ft 1in	
Max. Wind Speed	28mph	12.5m/s
Power		
Diesel Engine	Cummins QSF2.8	
Engine Power	75hp/2400rpm	54kW/2400rpm
Fuel Tank Capacity	39.6 (us gal)	150L
Auxiliary Power	12V	
Control Voltage	12V	
Hydraulic System Capacity	63.4 (us gal)	240L
Hydraulic Tank Capacity	47.6 (us gal)	180L
Drive	4WD	
Tire		
Type	15-625 Foam-filled Tires	
Weight		
Gross	40344 lb	18300kg

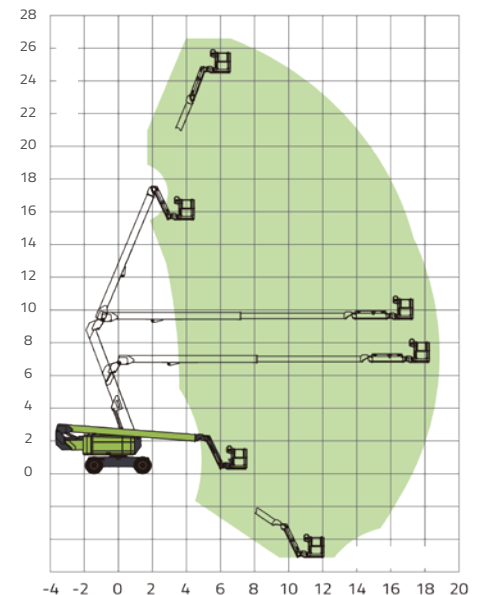
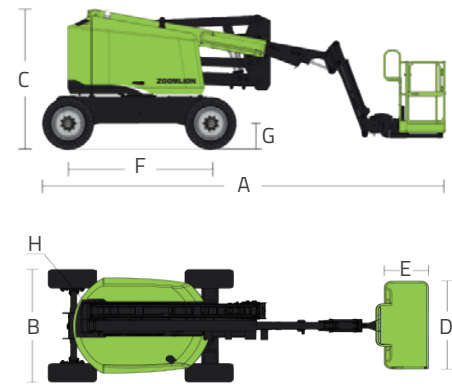

Range of Motion ZA80J